

Elstein HSR series

Elstein HSR high speed radiators are quick-reaction ceramic infrared panel radiators, designed for operating temperatures up to 860 °C and surface ratings up to 64 kW/m².

The external characteristics of the HSR radiators is their visible heating coil, which is installed in a ceramic body. This design shortens the heat-up and cool-down time up to 65 % as well as a reduced heat transfer to the wiring space.

HSR high speed radiators are particularly suitable for use in clocked production processes, for frequent tool changes or if the temperature has to drop quickly in case of transfer disruptions, in order to prevent damage of the production plant.

Elstein HSR high speed radiators are available in three designs and cover the power range from 125 W to 1000 W.

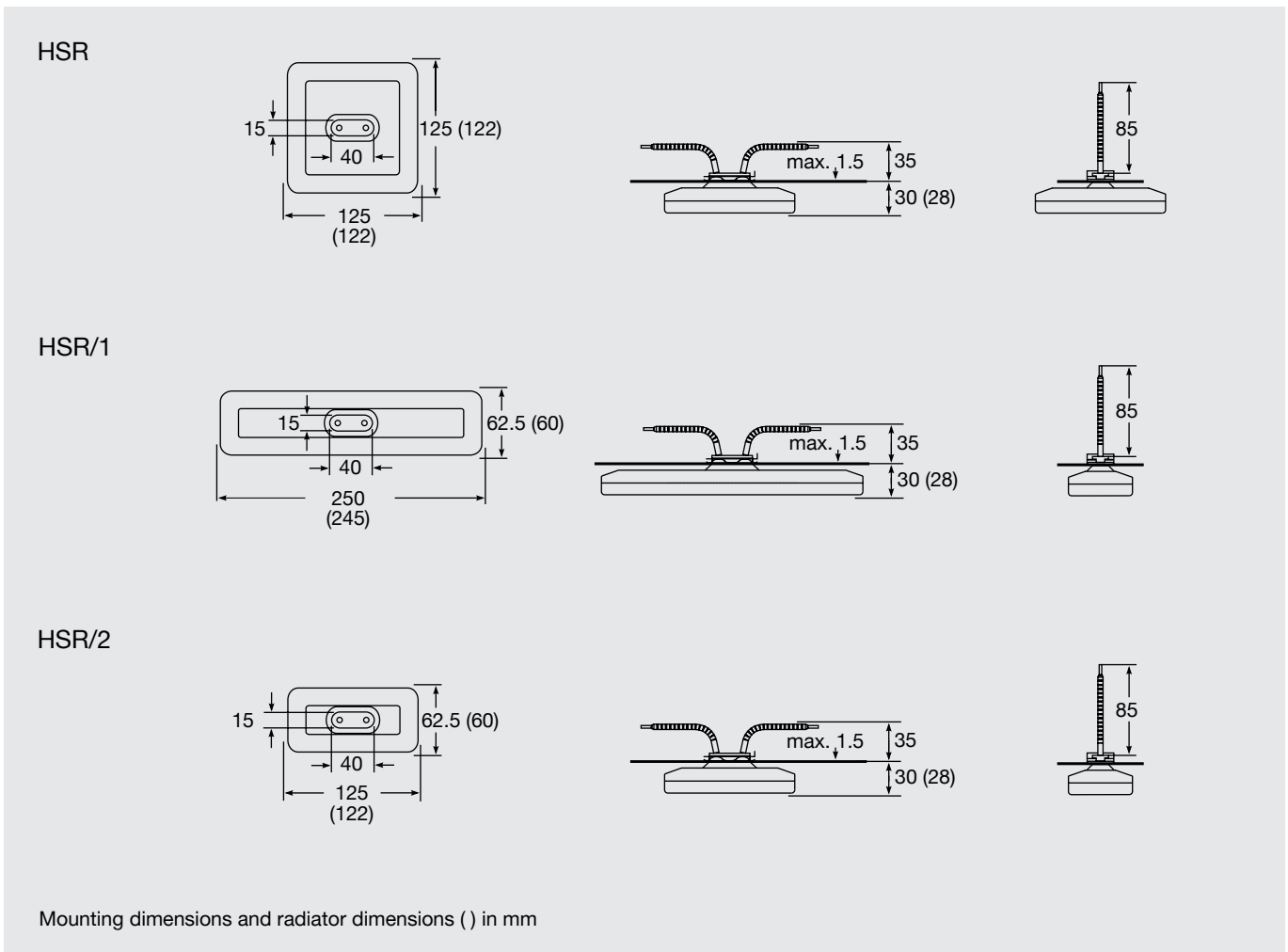

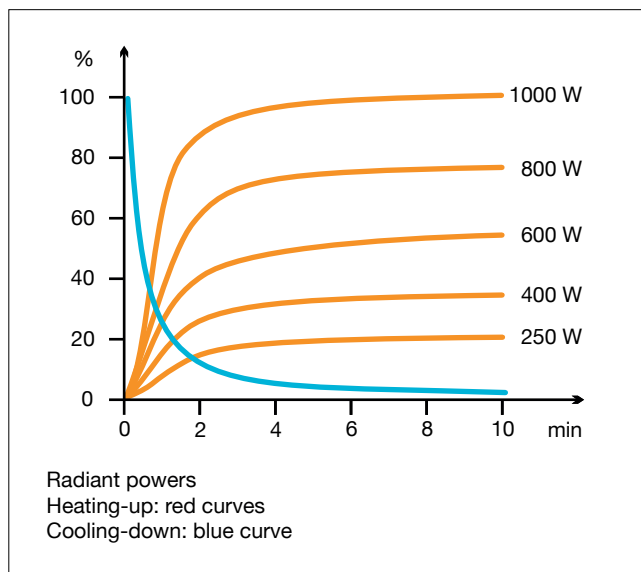
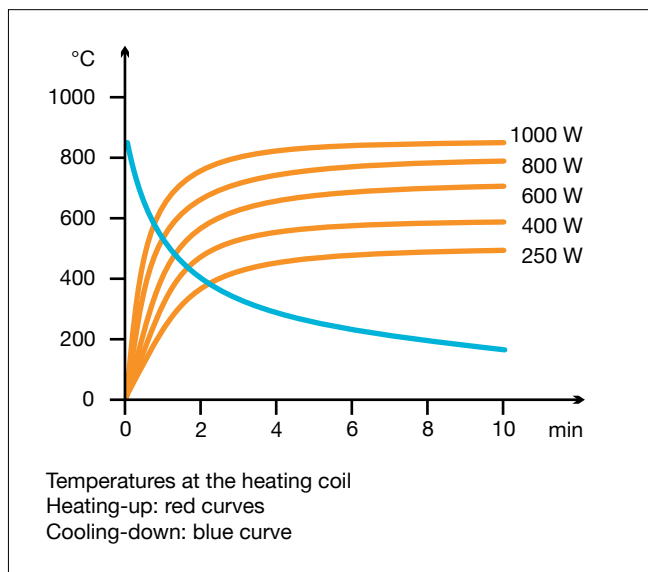

Type, weight, wattage	HSR	220 g	250	400	600	800	1000	W
	HSR/1	220 g	250	400	600	800	1000	W
	HSR/2	125 g	125	200	300	400	500	W
Surface rating			16.0	25.6	38.4	51.2	64.0	kW/m ²
Typical operating temperature			450	570	700	810	860	°C
Maximum permissible temperature			900	900	900	900	900	°C
Wavelength range			2 - 10					µm

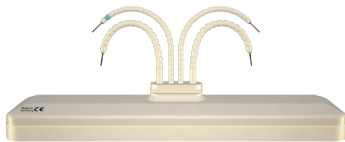
Standard design Operating voltage 230 V Ceramic moulding Integrated thermal insulation Leads 85 mm Elstein standard socket Mounting set	Thermocouple radiators Designation T-HSR, T-HSR/1, T-HSR/2 Integrated thermocouple Type K (NiCr-Ni) TC leads 100 mm 	Variants Special wattages Special voltages Extended leads Leads with ring terminals
--	---	--

The power can be controlled using thermocouple radiators together with TRD 1 temperature controllers, TSE thyristor switching units and other accessories.

IR radiation areas can be assembled using REO reflectors, REF construction sets, EBF and EBI construction elements, MBO mounting sheets as well as BSI construction panels.

The national safety regulations must be complied with for the respective application, for example, the IEC or EN standard 60519-1, Safety in electrical heating installations.



Important: The radiators of the HSR series must be installed and operated in a way, which does not enable touching the heaters (risk of injury due to electric shock). HSR series doesn't comply with REACH regulations.

Please observe our instructions for mounting, operation and safety.